

SC-1 WIRELESS ULTRA SOLAR CONTROLLER

INSTRUCTION MANUAL

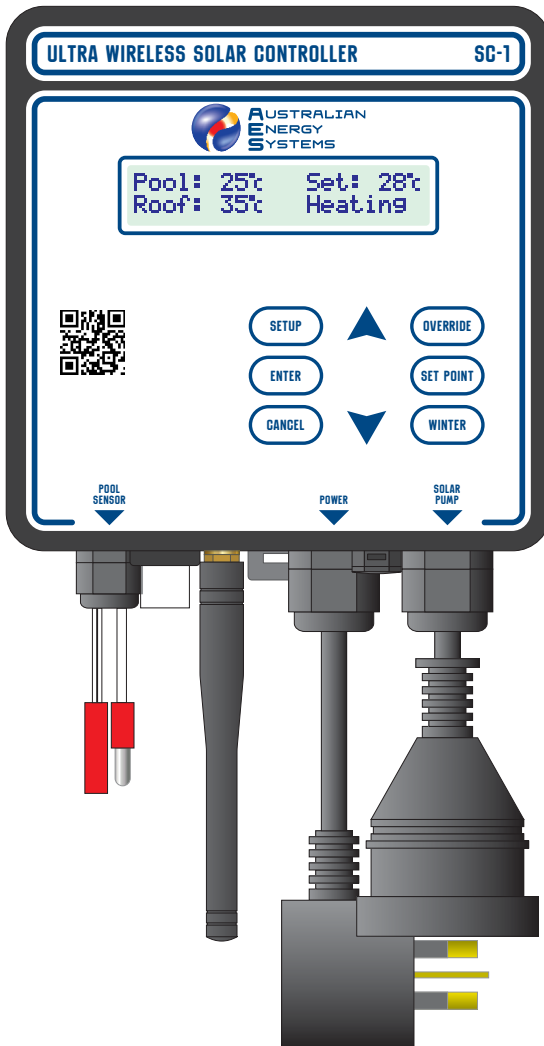



Thank you for purchasing the **SC-1 Ultra Wireless Solar Controller**.

The **SC-1** has been designed for maximum reliability and long service life. Please be sure to follow the instructions in this manual to get the best performance and life from your equipment.

The **SC-1** is quite easy to operate, and this manual will explain each of the steps clearly. Troubleshooting and hints are also included to allow you to get the most from your unit. If you require assistance at any stage, please contact your Australian Energy Systems Authorised Dealer.

	Page
CAUTIONS & WARNINGS	3
WHAT'S INCLUDED	3
GETTING TO KNOW YOUR SC-1	4
SC-1 DISPLAY.....	5
SC-1 UNIT INSTALLATION	6
POOL TEMPERATURE SENSOR INSTALLATION.....	7
WIRELESS ROOF TEMPERATURE SENSOR INSTALLATION	8
POWER AND PLUMBING CONNECTIONS, STANDALONE SYSTEM.....	11
POWER AND PLUMBING CONNECTIONS, INTEGRATED SYSTEM	12
HOW THE SC-1 WORKS.....	14
ADJUSTING THE SET POINT.....	14
OVERRIDE FUNCTION	14
WINTER MODE.....	15
COOLING MODE	15
START TIME	16
STOP TIME.....	16
SETTING THE CLOCK.....	17
TEMPERATURE UNITS	17
TEMPERATURE CALIBRATION	18
PAIRING A NEW TRANSMITTER	19
WIRELESS LINK INFORMATION	21
TROUBLESHOOTING	22
RESETTING THE CIRCUIT BREAKER.....	23
WARRANTY.....	24
CONTACT US.....	24



CAUTIONS & WARNINGS

- Please read the instructions fully and keep this manual on hand whenever operating or maintaining your **SC-1**.
- Although the **SC-1** has a weather resistant design, its service life will be considerably longer if it is not exposed to direct sunlight and rain. Wear and tear from direct exposure to the elements is not covered by the warranty.
- Keep the power cord visible. Do not bury it.
- Do not allow grass or weeds to grow around the **SC-1**, or its cables to prevent accidental damage from garden trimming equipment.
- Any damaged cables must be replaced immediately to prevent electrical shock.
- Unplug the **SC-1** power lead before inspecting or working on the pump.
- The **SC-1** must be serviced only by an authorised service agent. Please contact your Australian Energy Systems Authorised Dealer for details.
- Opening the unit may cause an electric shock, which can result in injury or death.



WHAT'S INCLUDED

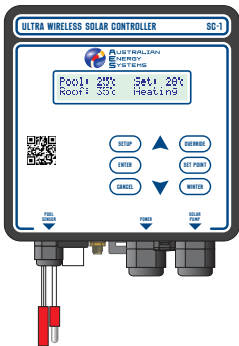

Ultra Solar **SC-1** Controller



SC-1W Wireless Transmitter



Roof Sensor (5m cable)



Antenna

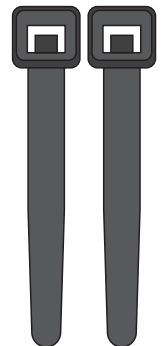

Cable Ties for mounting **SC-1W** (2)



Pool Temperature Sensor (3.5m cable)



Grommet for Pool Sensor

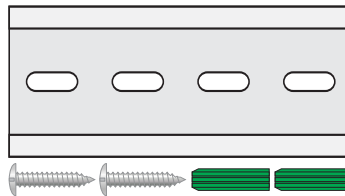

DIN Rail & Screw Kit for wall mounting unit

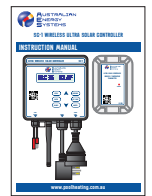

Instruction Manual

GETTING TO KNOW YOUR SC-1

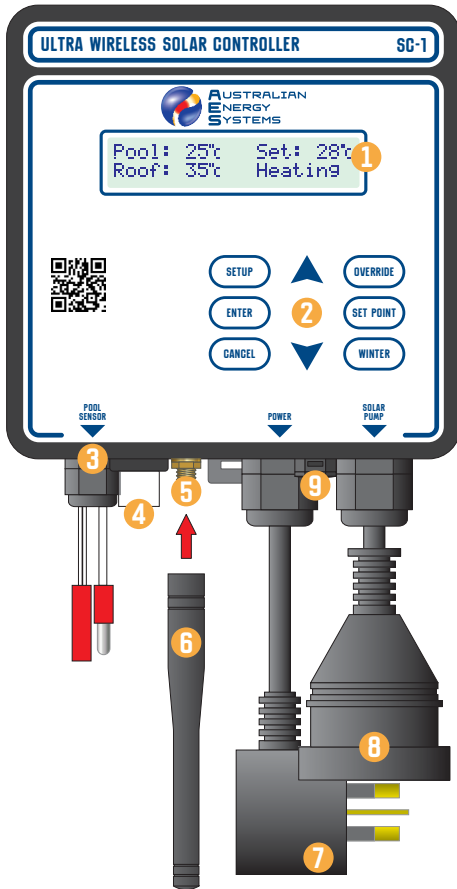

1 DISPLAY

User-friendly plain text menu and help system.

2 KEYPAD

Used for setup and maintenance of your **SC-1**. Three One-Touch buttons are provided for regularly accessed functions.

3 POOL SENSOR INPUT

Connect the Pool Temperature Sensor to the male and female 4mm bullet terminals.

4 CIRCUIT BREAKER

10 Amp Circuit Breaker with weatherproof cover protects the **SC-1** from power overload. Push the button in to reset if the breaker trips.

5 ANTENNA INPUT

SMA socket for antenna.

6 ANTENNA

915MHz Antenna, screws onto SMA socket.

7 POWER CORD

Piggyback power cord, which can be connected directly to a mains power point, or it can be connected to a pool filtration pump outlet. See pages 10 to 12.

8 SOLAR PUMP POWER OUTLET

Connect the solar heating pump to the Solar Pump power outlet socket.

9 VENT

Enclosure air vent to prevent condensation inside the **ESL-1**.

10 MOUNTING CLIP

Pull the clip downwards when mounting the **SC-1** to the mounting rail, or to unclip when removing.

11 SC-1W TRANSMITTER STATUS LED

The Status LED of the **SC-1W** Transmitter is used when pairing and testing the system, and in normal operation. See pages 19 & 20.



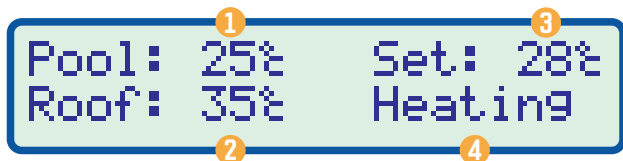

1 POOL TEMPERATURE

This is the readout of the current temperature of your pool water.

2 ROOF TEMPERATURE

This is the readout of the current roof temperature. It is not an air temperature measurement. It is the temperature inside a black tube that absorbs heat from the sun. Roof Temperature in some hot and sunny climates could exceed 70°C.

3 SET POINT

The **SC-1** maintains the pool temperature at the programmed Set Point.

4 STATUS

This is where **SC-1** indicates helpful messages and warnings, so you know what's happening at all times.

Heating.....The Solar Pump output is switched on to heat the pool because the current pool temperature is below the Set Point.

Cooling.....The Solar Pump output is switched on to cool the pool because the current pool temperature is above the Set Point. This function works at night, and is used to cool the pool in hot areas.

Purging.....The **SC-1** runs the Solar Pump for 5 minutes every 3 hours to ensure that the pool temperature reading is correct. The last purge each day is at the Stop Time. See page 15.

On Delay.....The Solar Pump is switched off for 3 hours after the **SC-1** reached the Set Point.

Over:On.....The Override function has been set to ON, and the Solar Pump will operate regardless of Pool and Roof Temperature readings. Note that the Solar Pump will be switched off if the pool temperature reaches 40°C.

The **SC-1** reverts to Auto mode at the Stop Time. See page 15.

Over:Off.....The Override function has been set to OFF, and the Solar Pump will not operate, regardless of Pool and Roof Temperature readings.

The **SC-1** reverts to Auto mode at the Stop Time. See page 15.

Winter.....The **SC-1** is in Winter mode. The heating function is disabled, and the Solar Pump runs for 5 minutes at Midday each day to help preserve the seals and other parts of the system.

Overheat.....Pool Temperature is 40°C or higher, so the Solar Pump is OFF.

Chk Batt.....**SC-1W** Roof Transmitter battery may be aged. See page 23.

No Flow.....The optional Flow Switch is installed, and there is no water flow in the pipe.

PRE-INSTALLATION CHECKLIST

- The **SC-1** unit **MUST** be mounted vertically, with the cables at the bottom in order to be weather resistant. Any water ingress due to the unit being incorrectly mounted is not covered by warranty.
- Choose a position that will allow the cable from the Pool Temperature Sensor to reach the **SC-1** without straining.
- Ensure that the power lead from the Solar Pump can reach the power outlet on the **SC-1** without straining. The power outlet socket must be hanging downwards to be weather resistant.
- Ensure that the **SC-1** is protected from direct sunlight and weather. Although the unit has a weather resistant design, damage from long term exposure is not covered by the warranty.
- Do not connect the **SC-1** power lead to the power source until all installation steps are complete.

INSTALL MOUNTING PLATE

Install the mounting plate level in the desired location. Screws and wall plugs are provided.

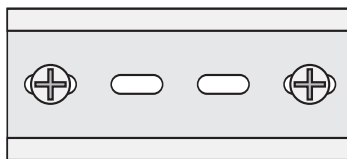

MOUNT SC-1 UNIT

- ① Hook the **SC-1** mounting clip onto the top rail of the mounting plate.
- ② Pull the mounting clip down, pushing the **SC-1** against the bottom rail of the mounting plate.
- ③ Allow the mounting clip to lock in place behind the bottom rail.

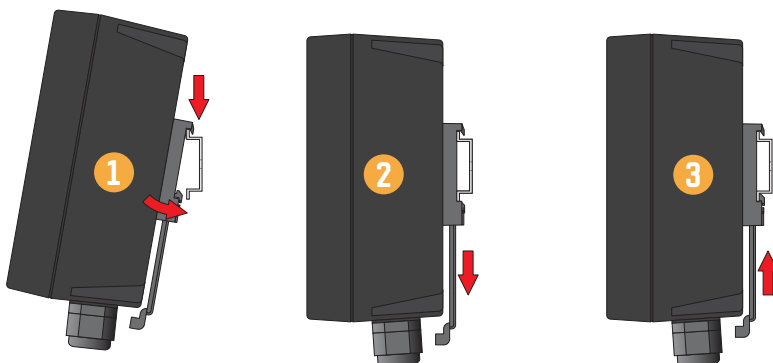



POOL TEMPERATURE SENSOR INSTALLATION

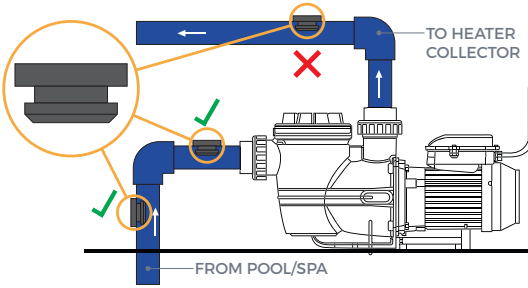

SELECT POOL SENSOR LOCATION

Install the Pool Temperature Sensor in the suction line before the solar pump. The grommet is designed to be fitted into the pipe, not into thicker walled PVC fittings.

The Pool Temperature Sensor can be mounted in any orientation, in a convenient location of the pipe.

SELECT DRILL BIT AND DRILL PIPE

You will require a drill with a 12mm or 1/2" Drill. Spade and Wood bits are preferred to HSS Metal drill bits. If a HSS Metal drill bit must be used, run the drill backwards to prevent pipe damage.

Drill the hole in the selected pipe location and remove any burrs before installing the grommet.

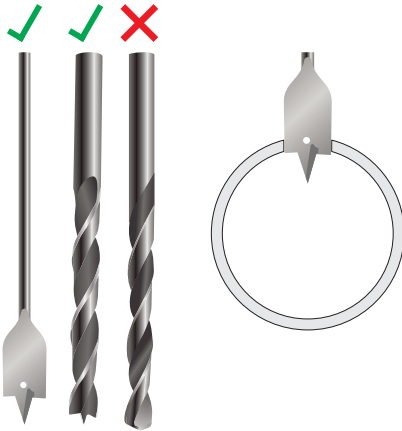

INSTALL THE GROMMET

Push the grommet into the hole, making sure that it is evenly seated all around.

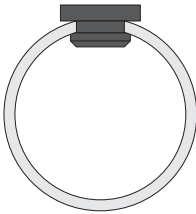

INSTALL POOL TEMPERATURE SENSOR

Push the Pool Temperature Sensor all the way into the grommet.

Connect the male and female bullet connectors to the **POOL SENSOR** input of the **SC-1**.

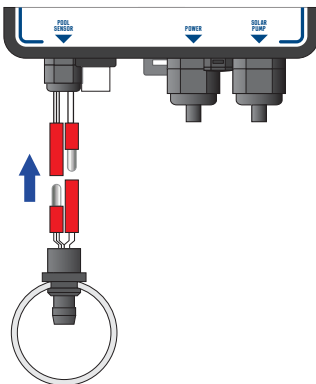



WIRELESS ROOF TEMPERATURE SENSOR INSTALLATION

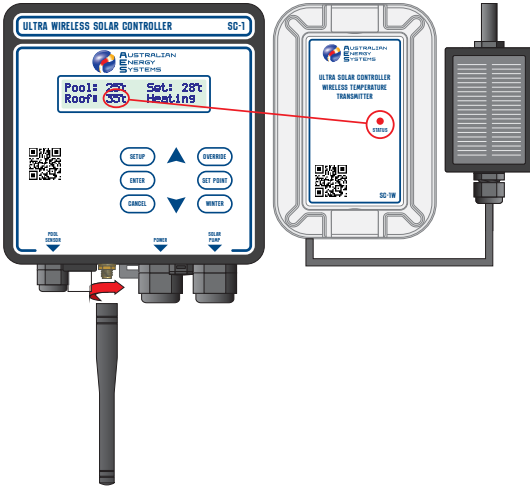

ENSURE THAT SC-1W IS PAIRED TO SC-1

The **SC-1W** Transmitter is supplied pre-paired to the **SC-1** Controller. Before installation, ensure that this pairing is still correct.

- Screw the antenna onto the SMA socket of the **SC-1** Controller.
- Ensure that the **SC-1W** Transmitter is in full sun, so that its internal battery is being charged.
- Switch on the **SC-1** Controller.
- When the **SC-1** Controller is paired correctly with the **SC-1W** Transmitter, a valid Roof Temperature will be displayed within 3 minutes.
- Refer to page 19 if the **SC-1** Controller and **SC-1W** Transmitter are not communicating and need to be re-paired.



WIRELESS ROOF TEMPERATURE SENSOR INSTALLATION

CONNECT SOLAR SENSOR TO SC-1W

Align the keyway of the Solar Sensor plug with the socket of the **SC-1W** Wireless Transmitter.

Push the plug into the socket, then screw down the retaining ring firmly.

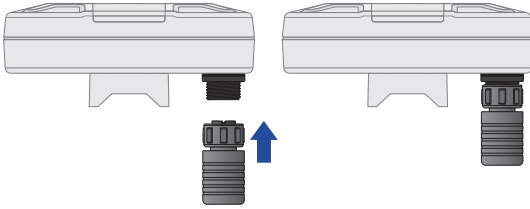

MOUNT SC-1W TRANSMITTER TO PIPE

- Mount the **SC-1W** Transmitter to the cold or hot water pipe going to or from the heater collector on the roof.
- Mount as close as practical to the eave, to shelter the **SC-1W** from direct sun and weather. The **SC-1W** can be mounted vertically or horizontally, as needed.
- Fix the **SC-1W** in place with the two cable ties supplied.

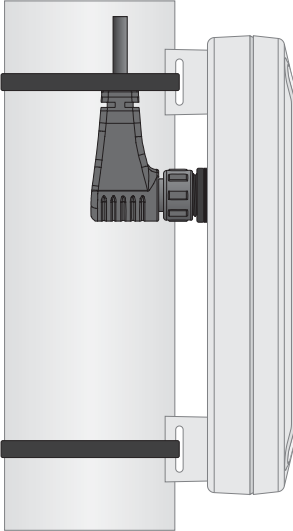

- **DO NOT MOUNT THE SC-1W DIRECTLY ON THE ROOF, EXPOSED TO DIRECT SUN AND WEATHER.**

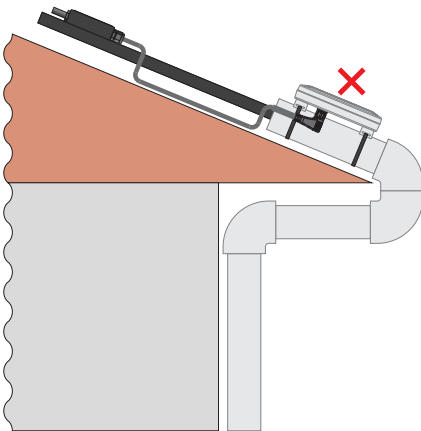



WIRELESS ROOF TEMPERATURE SENSOR INSTALLATION

INSTALL SOLAR SENSOR

Mount the Solar Panel / Temperature Sensor (Solar Sensor) in a suitable location on the roof, without straining the cable or connector.

The Solar Sensor is normally mounted alongside the heater collector mats, however it can be mounted on any surface that is at the same angle to the sun as the collector mats.

Make sure that the Solar Sensor will not be shaded by trees, other roofs etc when the collector mats are in the sun. Watch for young trees and shrubs that may grow in the future.

Use UV resistant cable ties to neatly tie the Solar Sensor cable to the pipe up to the roof.

Coil extra cable underneath the collector mats to keep it safe from birds and other damage.

Glue the Solar Sensor onto the collector mat or roof surface with a high quality silicone based sealant.

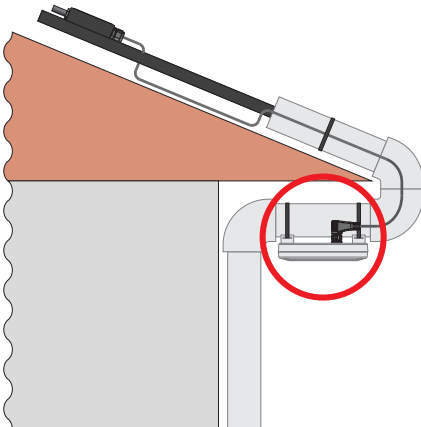
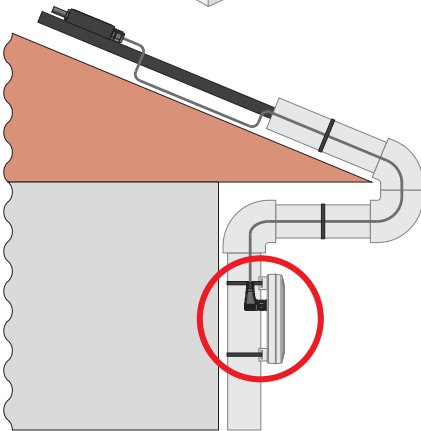
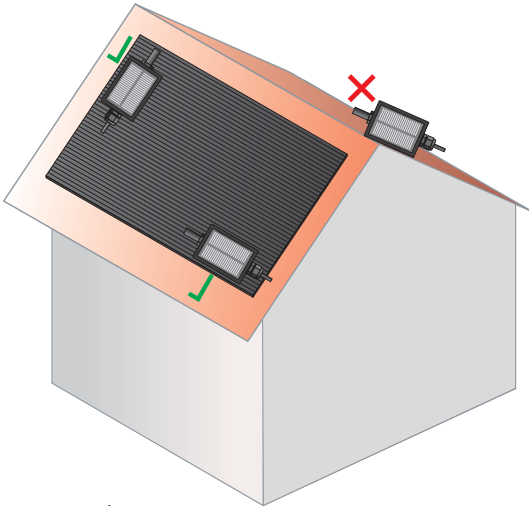



POWER AND PLUMBING CONNECTIONS

STANDALONE SYSTEM (SEPARATE SOLAR PROVISIONS)

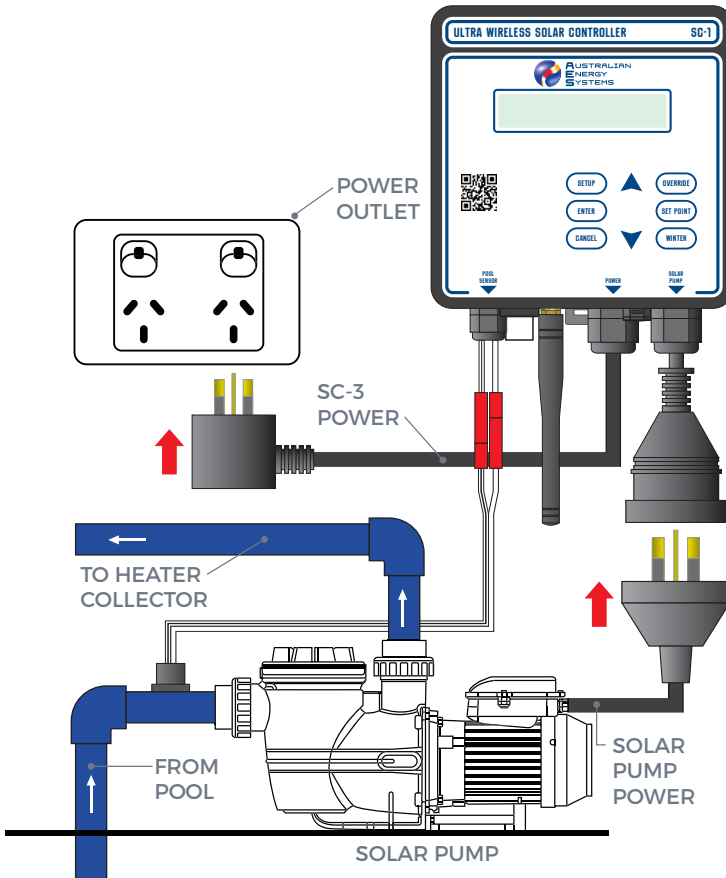

- Connect the **SC-1** power lead to a suitable 10 Amp rated, weather resistant power outlet.
- Connect the Solar Pump to the **SOLAR PUMP** outlet of the **SC-1**.
- For Standalone Systems, the plumbing connections will take cold water from the pool, pump that to the heater collectors, and return the heated water back to the pool through separate solar plumbing provisions.



POWER AND PLUMBING CONNECTIONS

INTEGRATED SYSTEM (SHARED SOLAR PROVISIONS)

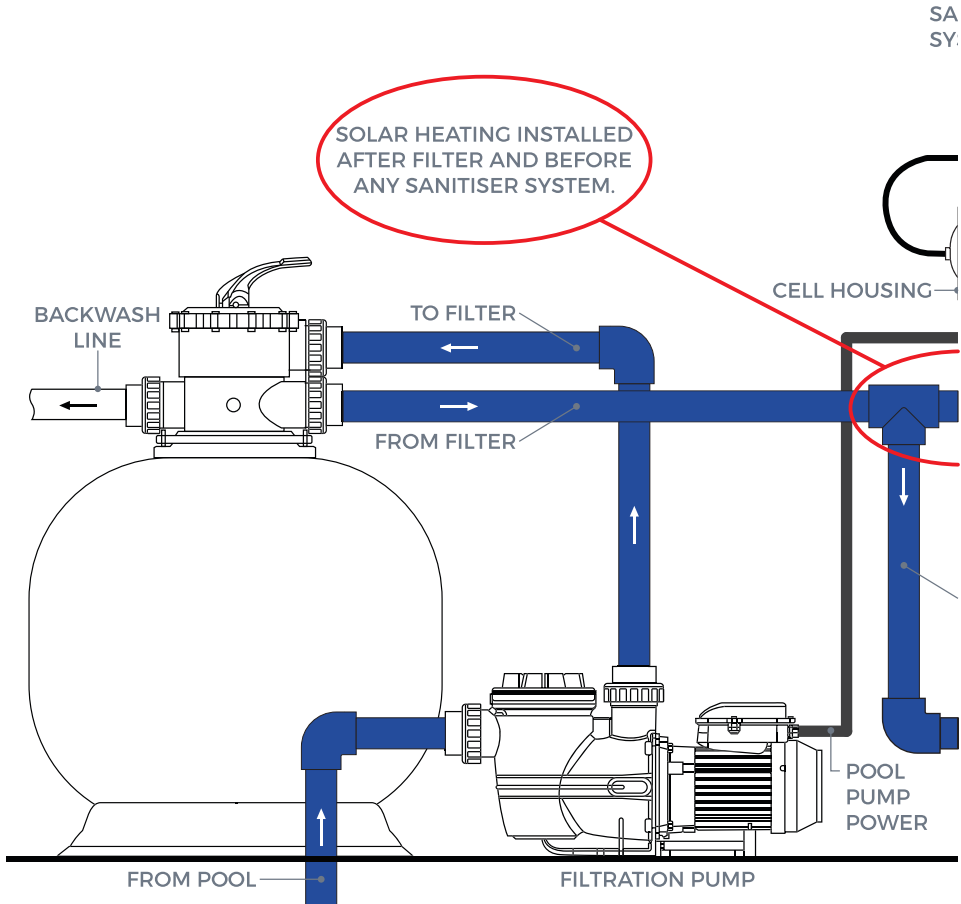

POWER CONNECTIONS

- Connect the Sanitiser System power lead to a suitable 10 Amp rated, weather resistant power outlet.
- Connect the **SC-1** power lead to the Sanitiser System pool pump outlet.
- Connect the Pool Pump power lead into the piggy-back socket of the **SC-1** power lead.
- Connect the Solar Pump to the **SOLAR PUMP** outlet of the **SC-1**.

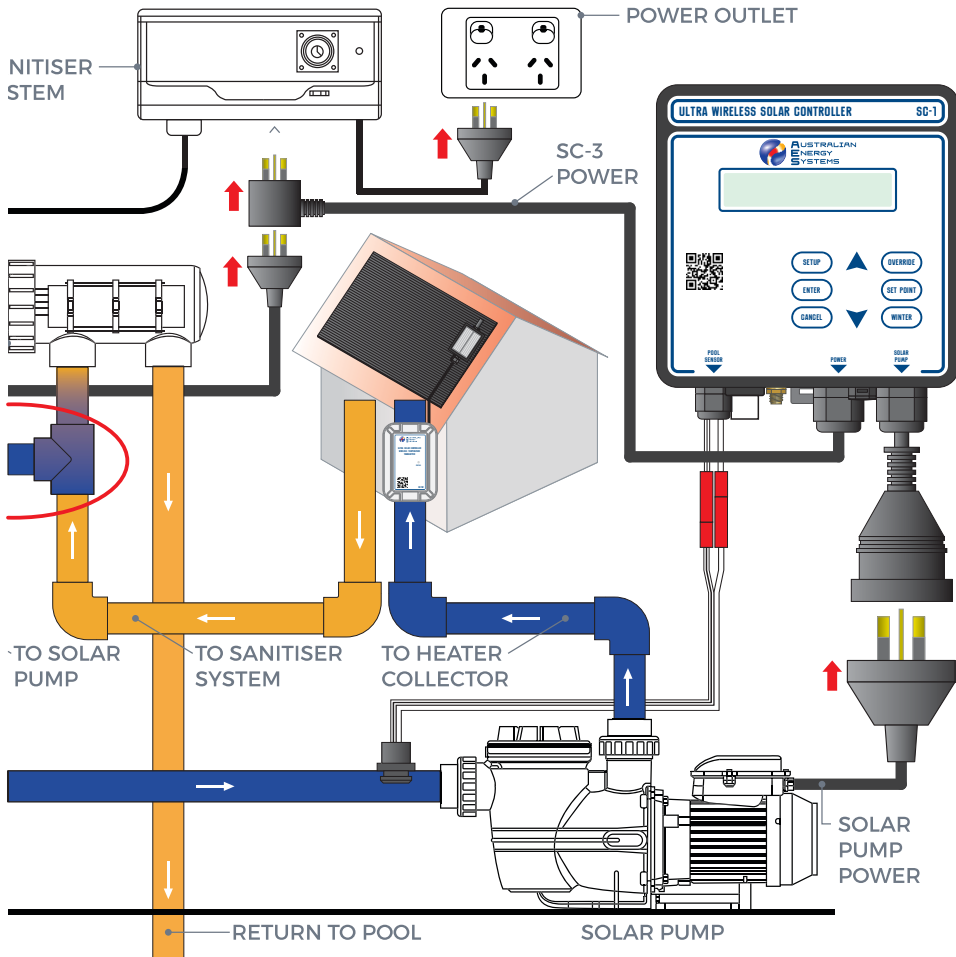

PLUMBING CONNECTIONS

- Plumb the suction line of the Solar Pump into the pool return line after the filter, and before the heated water return from the Heater Collector.
- Plumb the heated water line into the pool return line after the solar pump take-off and before the Sanitation System.
- The water flow for the Solar Heating must always be before any type of Sanitation System to prevent damage to the Heater Collectors from high sanitiser levels.



HOW THE SC-1 WORKS

For most applications, the **SC-1** can be simply installed and switched on without any further adjustment.

The default set point is 28.0 °C with a 1.0 °C control band. This means that the solar pump will be switched ON when the water temperature falls below 27.0 °C, and back OFF again when the water temperature rises above 28.0 °C.

When heating, the solar pump will only operate when the roof temperature is at least 5°C hotter than the pool temperature.

When cooling, the solar pump will only operate when the roof temperature is at least 5°C cooler than the pool temperature.

When the solar pump is switched OFF, the **SC-1** will purge the system with fresh pool water every 3 hours to ensure that the pool temperature reading is correct.



ADJUSTING THE SET POINT

- Press the **SET POINT** button. The current setting is now displayed.
- Press **▲** and **▼** buttons to adjust the Set Point to the desired setting. The adjustment range is 20 to 40 °C.
- Press **ENTER** to save the new setting or press **CANCEL** to quit without saving.

SET POINT

```

Set Point: 28.0
Set: ▲▼   Save: Enter
  
```



OVERRIDE FUNCTION

- Press the **OVERRIDE** button.
- Press **▲** and **▼** buttons to select between the following settings:

OVERRIDE

```

Override: AUTO
Set: ▲▼   Save: Enter
  
```



```

Override: ON
Set: ▲▼   Save: Enter
  
```



```

Override: OFF
Set: ▲▼   Save: Enter
  
```

AUTO..... Normal Automatic pool heating control.

ON..... Switch Solar Pump ON, even if heating is not required.

The Solar Pump will switch off if the water temperature reaches 40 °C.

The **SC-1** will change back to **AUTO** at programmed Stop Time (see page 15).

OFF..... Switch Solar Pump OFF, even when heating is required.

The **SC-1** will change back to **AUTO** at programmed Stop Time (see page 15).

- Press **ENTER** to save the new setting or press **CANCEL** to quit without saving.



WINTER MODE

Winter mode is used to stop heating when there is not enough solar energy to heat the pool sufficiently during the winter months. In Winter mode, the **SC-1** will run the solar pump for 5 minutes per day, to help preserve seals and other parts of the system.

To select Winter Mode:

- Press the **WINTER** button.
The **SC-1** will confirm that it is now in Winter Mode.

To select Summer Mode:

- Press the **WINTER** button when the **SC-1** is in Winter mode.
The **SC-1** will confirm that it is now in Summer Mode. Normal solar pool heating control will resume.

WINTER

Winter Mode. Pump
will run 5 mins/day.



5 seconds

Pool: 20% Winter
Roof: 30%

WINTER

Summer Mode. Normal
heating will resume.



5 seconds

Pool: 25% Set: 28%
Roof: 35% Heating



COOLING MODE

In tropical areas, the **SC-1** can cool the pool during the night if the pool temperature is too high. When Cooling Mode is on, the controller will cool the pool at night and heat it during the day, depending on the pool and roof temperatures. It is advisable to reduce the Set Point when Cooling Mode is on.

To set Cooling Mode to On or Off:

- Press the **SETUP** button.
- Press the **▲** and **▼** buttons until **Cooling Mode** is displayed. The current setting is displayed in brackets. The default setting is OFF.
Press **ENTER** to change the setting.
- Press the **▲** and **▼** buttons to set Cooling Mode to ON or OFF.
- Press **ENTER** to save the new setting, or press **CANCEL** to quit without saving.

When Cooling Mode is set to ON, change the Stop Time for the solar pump to a later time during the night or for 24 hour operation. See page 15.

SETUP



Cooling Mode (OFF)
Scroll:▲▼ Set:Enter

ENTER

Cooling Mode : OFF
Set:▲▼ Save:Enter



START TIME

In some areas, there is enough solar energy to start the solar pump very early in the morning, resulting in high noise levels for you and your neighbours. The default setting is 7:00am. The **SC-1** allows you to set the earliest start time:

- Press the **SETUP** button.
- Press the **▲** and **▼** buttons until **Start Time** is displayed. The current setting is displayed in brackets. The default setting is 7:00AM. Press **ENTER** to change the setting.
- Press the **▲** and **▼** buttons to set the earliest time of day to start operating the solar pump. The allowable range is 6:00am to 6:00pm. The late Start Time allows for installations where the only requirement is for cooling at night.
- Press **ENTER** to save the new setting, or press **CANCEL** to quit without saving.



```
Start Time (07:00)
Scroll:▲▼ Set:Enter
```



```
Start Time: 07:00
Set:▲▼ Save:Enter
```



STOP TIME

The Stop Time is the latest time that the **SC-1** will run the solar pump each day.

If Cooling Mode is enabled, this should be set to late into the night. It can even be set after midnight and the **SC-1** software will operate correctly.

To allow the solar pump to run 24 hours per day as needed for heating or cooling, set the Stop Time to the same time as the Start Time.

- Press the **SETUP** button.
- Press the **▲** and **▼** buttons until **Stop Time** is displayed. The current setting is displayed in brackets. The default setting is 19:00 (7:00PM). Press **ENTER** to change the setting.
- Press the **▲** and **▼** buttons to set the latest time of day to stop operating the solar pump.
- Press **ENTER** to save the new setting, or press **CANCEL** to quit without saving.



```
Stop Time (19:00)
Scroll:▲▼ Set:Enter
```



```
Stop Time: 19:00
Set:▲▼ Save:Enter
```



SETTING THE CLOCK

- Press **SETUP** button.
- Press **▲** and **▼** until **Set Clock** is displayed. The current time is shown in brackets.
- Press **ENTER** to set the clock.
- Press **▲** and **▼** to set the clock hours. This is in 24 hour format. Hold down the **▲** or **▼** button to scroll quickly.
- Press **Enter** to save the clock hours.
- Press **▲** and **▼** to set the clock minutes. Hold down the **▲** or **▼** button to scroll quickly.
- Press **ENTER** to save the clock minutes.
- The **SC-1** will now return to normal operation.

The **SC-1** clock is backed up by a super capacitor when power is lost. This will maintain the correct time for several days without needing to reset the clock.



TEMPERATURE UNITS

- Press **SETUP** button.
- Press **▲** and **▼** until **Temp Units** is displayed. The current setting is shown in brackets. The default setting is °Celsius.
Press **ENTER** to change the setting.
- Press the **▲** and **▼** buttons to set the Temperature Units to °C or °F.
- Press **ENTER** to save the new setting, or press **CANCEL** to quit without saving.

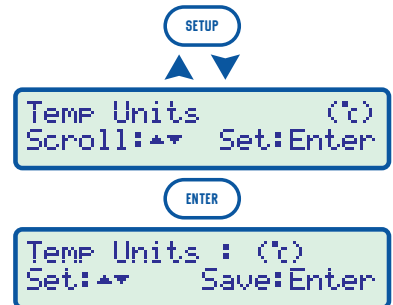



TEMPERATURE CALIBRATION

The **SC-1** is pre-calibrated to the Pool Temperature sensor supplied in the kit.

Re-calibrating the Pool Temperature sensor should only be required if the sensor is replaced.

The Wireless Roof Temperature sensor does not require calibration, even if the sensor and/or **SC-1W** transmitter are replaced.

- If the Pool Temperature sensor will be removed from the pipe, select Override:Off mode beforehand to ensure that the Solar Pump does not start. See page 12.
- Place the Pool Temperature sensor into a beaker of water, alongside an accurate reference thermometer. Stir the water to ensure an even temperature throughout.
- Press the **SETUP** button.
- Press the **▲** and **▼** buttons until **Calibrate Pool Temp** is displayed.

Press **ENTER** to begin calibration. The following data is displayed on the calibration screen:

- 1** The raw temperature reading from the sensor, without any calibration adjustment applied.
- 2** The calibrated temperature reading with calibration adjustment applied.
- 3** The number of degrees of temperature offset to calibrate the reading to match the reference thermometer.
- 4** The value that will be displayed in normal operation, rounded to 1°C resolution.

- Press the **▲** and **▼** buttons to set the calibrated value to match the reference thermometer.
- Press **ENTER** to calibrate the Pool Temperature sensor, or press **CANCEL** to quit without re-calibrating.
- The **SC-1** will return to the normal display, and be in Override:Off mode. Install the Pool Temperature sensor into the pipeline before changing to AUTO mode. See page 13.

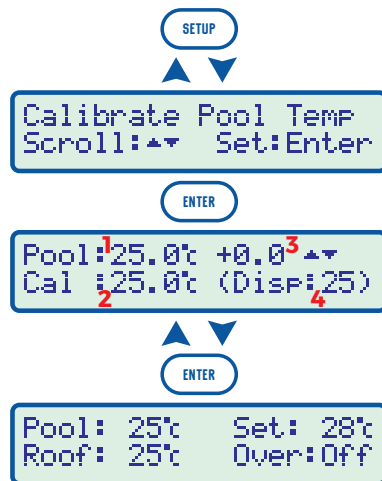

↻ PAIRING A NEW TRANSMITTER

The **SC-1W Transmitter** and **SC-1 Controller** are paired at the factory before being packed. If this pairing has been lost, or if the **SC-1W Transmitter** or **SC-1 Controller** is replaced in the future, this section explains how to pair the two devices.

① Ensure that the current **SC-1W Transmitter** is not communicating with the **SC-1 Controller**.

- If “**No RF**” is already being displayed for the Roof Temperature on the **SC-1 Controller** display, then the current **SC-1W Transmitter** is not communicating. Skip to Step 2.
- If there is a valid Roof Temperature reading on the **SC-1 Controller** display, or an error message such as **Low** or **Short**, then put the **SC-1W Transmitter** to sleep first:
 - Unplug the Roof Sensor from the **SC-1W**.
 - Within 2 minutes, the **SC-1 Controller** will show “**Sleep**” instead of a Roof Temperature.
 - 10 minutes after “**Sleep**”, the **SC-1 Controller** will stop trying to communicate with the **SC-1W Transmitter**, and show “**No RF**”. A new **SC-1W Transmitter** can be paired with the **SC-1 Controller** at this time.



Pool: 25°C	Set: 28°C
Roof: 25°C	12:00

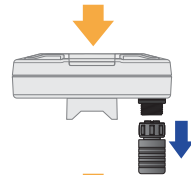

↓ 2 minutes



Pool: 25°C	Set: 28°C
Roof: Sleep	12:02

↓ 10 minutes

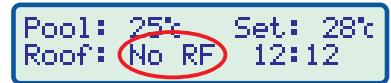

Pool: 25°C	Set: 28°C
Roof: No RF	12:12

② Put the **SC-1W Transmitter** into pairing mode:

- Switch the **SC-1W Transmitter** on, by connecting the Roof Sensor.
- If the **STATUS** LED alternates between Red and Blue every 5 seconds, then the **SC-1W** has already been set for pairing mode. Skip to Step 3.
- If the Roof Sensor is **NOT** in pairing mode, follow these steps to put it into pairing mode:
 - Unplug the Roof Sensor from the **SC-1W**.
 - Within the next 2 minutes, the **STATUS** LED will first flash red, then change to flashing blue. While the LED is flashing blue, re-connect the Roof Sensor.
 - The **STATUS** LED will flash red again, then change to flashing blue. While the LED is flashing blue, unplug the Roof Sensor again.
 - The **STATUS** LED will flash red again, then change to flashing blue. While the LED is flashing blue, re-connect the Roof Sensor.
- The **SC-1W** will now enter Pairing mode, which is indicated by the **Status LED** alternating between Red and Blue every 5 seconds.

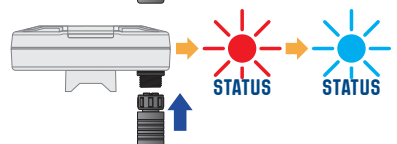
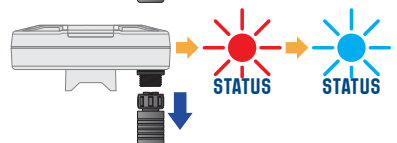
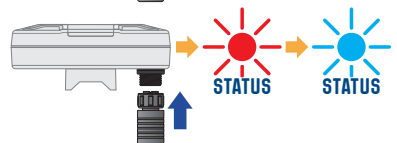
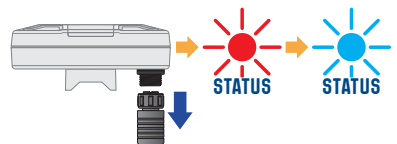



PAIRING A NEW TRANSMITTER

3 Pair the SC-1 Controller with the new SC-1W Transmitter:

- If the **SC-1** Controller was showing “No RF” as detailed in Step 1, and the **SC-1W** Transmitter was put into pairing mode as per Step 2, the **SC-1** Controller will now show “Pair?” instead of a Roof Temperature reading.

```
Pool: 25° Set: 28°
Roof: Pair? 12:12
```

SETUP



```
Wireless Roof Setup
Scroll:▲▼ Set:Enter
```

ENTER

```
Pair New Transmitter
Scroll:▲▼ Set:Enter
```

ENTER

```
Pair New Transmitter
You Sure? Yes:Enter
```

ENTER

```
Finding Roof
Transmitter
```



```
Pool: 25° Set: 28°
Roof: Pair? Pairing
```



```
Pool: 25° Set: 28°
Roof: 25° 12:15
```

- Press the **SETUP** button.
- Press the **▲** and **▼** buttons until **Wireless Roof Setup** is displayed and Press **ENTER**.
- Press the **▲** and **▼** buttons until **Pair New Transmitter** is displayed and Press **ENTER**.

- The **SC-1** will now ask you to confirm that you wish to pair a new transmitter.

Press **ENTER** to continue to pairing, or **CANCEL** to quit without pairing.

- The **SC-1** Controller is now ready to find the new **SC-1W** Transmitter and displays the message “**Finding Roof Transmitter**”.

If the **SC-1** Controller displays the message “**Transmitter is already paired**”, then you are either attempting to pair the current Transmitter, or the current Transmitter is still switched on. Start again at Step 1.

- When the **SC-1** Controller has found the new **SC-1W** Transmitter, the unit returns to the main screen, and shows “**Pairing**” on the bottom, right.

- When pairing is complete, a valid Roof Temperature will be displayed, with either the time or status on the bottom, right.



WIRELESS LINK INFORMATION

The **SC-1** Controller can display information about the wireless link to the **SC-1W** Transmitter. This can be useful when trying to diagnose possible communication problems between the **SC-1** and the **SC-1W**.

- Press the **SETUP** button.
- Press the **▲** and **▼** buttons until **Wireless Roof Setup** is displayed and Press **ENTER**.
- Press the **▲** and **▼** buttons until **Wireless Roof Info** is displayed and Press **ENTER**.

Bat:..... Current Volts (v) in the **SC-1W** battery. The following percentages are a guide only, and depend on the condition and temperature of the battery:

100%.....2.80v 80%.....2.54v 60%.....2.52v
40%.....2.48v 20%.....2.42v

Qx:..... Battery condition, from Q1 to Q20. Q1 is best and by the time the battery condition falls to Q10 or higher (normally after several years), it should be replaced.

xxmA:.... The charge rate going from the solar panel to the battery, in Milliamps (mA). The mA will depend on brightness of the sun and the current level of charge already stored in the battery.

Roof: The current temperature reading from the Roof Sensor.

Int:..... The current temperature reading from inside the **SC-1W** enclosure.

- Press the **▲** and **▼** buttons to toggle between the two pages of Wireless Link Information:

1a2b:3c4d The hex wireless addresses of the **SC-1** Controller and the **SC-1W** Transmitter.

Sx: Wireless signal strength. Maximum = 9.

TX ok/ ... An indicator that data was transmitted

No TX: and a receipt was received in reply.

RX: The number of seconds since the last successful data transmission from the **SC-1W** to the **SC-1**.

Stable.... Indicates that the **SC-1W** is operating correctly and all data packets are being successfully received.

UnStbl ... Indicates the **SC-1W** has rebooted due to extreme low battery.

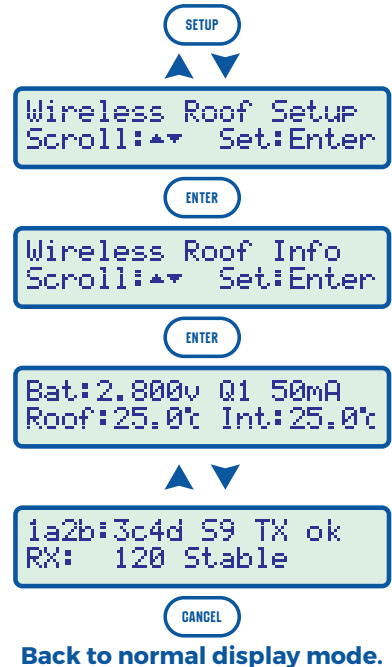



Back to normal display mode.

❓ TROUBLESHOOTING

Pool Temp Messages	Possible Causes and Remedies
<div style="border: 1px solid black; padding: 5px; margin-bottom: 10px;"> Pool: Low Set: 28°C Roof: 25°C 12:00 </div>	<p>Pool Temperature shown as “Low”.</p> <ul style="list-style-type: none"> • The sensor is open circuit (e.g. wire has been cut). • The sensor is faulty and measuring a false very low reading. • The temperature is 2.0°C or lower. <p>If the temperature really is 2.0°C or lower, then no action is required.</p> <p>Alternatively, repair the cut wire or replace the faulty sensor.</p>
<div style="border: 1px solid black; padding: 5px;"> Pool: Short Roof: 25°C 12:00 </div>	<p>Pool Temperature shown as “Short”.</p> <ul style="list-style-type: none"> • A short circuit has been detected in the Pool Temperature sensor. <p>Replace the Pool Temperature sensor.</p>
Roof Temp Messages	Possible Causes and Remedies
<div style="border: 1px solid black; padding: 5px; margin-bottom: 10px;"> Pool: 25°C Set: 28°C Roof: Low 12:00 </div>	<p>Roof Temperature shown as “Low”.</p> <ul style="list-style-type: none"> • The SC-1 Controller was powered up, and has not yet receive a Roof Temperature reading from the SC-1W Transmitter. • The sensor is faulty and measuring a false very low reading. • The temperature is 2.0°C or lower. <p>If the temperature really is 2.0°C or lower, then no action is required.</p>
<div style="border: 1px solid black; padding: 5px; margin-bottom: 10px;"> Pool: 25°C Set: 28°C Roof: Short 12:00 </div> <div style="border: 1px solid black; padding: 5px;"> Pool: 25°C Set: 28°C Roof: Open 12:00 </div>	<p>Roof Temperature shown as “Short” or “Open”.</p> <ul style="list-style-type: none"> • A short or open circuit has been detected in the Roof Temperature sensor. <p>Replace the Roof Temperature sensor.</p>
<div style="border: 1px solid black; padding: 5px; margin-bottom: 10px;"> Pool: 25°C Set: 28°C Roof: Sleep 12:00 </div> <div style="border: 1px solid black; padding: 5px;"> Pool: 25°C Set: 28°C Roof: No RF 12:00 </div>	<p>Roof Temperature shown as “Sleep” or “No RF”.</p> <ul style="list-style-type: none"> • SC-1 Controller is not receiving data from SC-1W Transmitter. • NiMH Battery may be faulty. Check and replace if necessary. • A short circuit has been detected in the Roof Temperature sensor. Replace the Roof Temperature sensor.

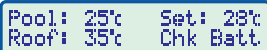
? TROUBLESHOOTING

Hardware Error Messages	Explanation of Message
	<ul style="list-style-type: none">• The SC-1W is in shade for too much of the daylight hours.• The rechargeable battery in the SC-1W Transmitter is aged. <p>Check that the SC-1W is full sun for most of the day. Have any trees grown up since the SC-1W was installed?</p> <p>Replace the SC-1W battery. Please contact your Australian Energy Systems Authorised Dealer.</p>
	<ul style="list-style-type: none">• The SC-1 has not been able to obtain data from the internal clock chip.• Press Cancel to restart, or switch the SC-1 off for 5 seconds, then back on again. If problem persists, return the unit for repair.
General Messages	Explanation of Message
	<ul style="list-style-type: none">• This message is displayed each time the SC-1 is switched on.• If you need to contact us for technical support, we may ask you the software version number ("v1.1" in this example).



RESETTING THE CIRCUIT BREAKER

The **SC-1** has a 10 Amp circuit to protect the unit from excessive power drain from the Solar Pump or internal fault. This could be due to the Solar Pump being rated to higher than 10 Amps, or has an unusually high start-up current, or is faulty. For example, a faulty start-up and run capacitor.

Other factors can also cause the circuit breaker to blow, but those listed above are the most common. If the circuit breaker continues to blow, the problem causing this situation must be rectified.

To re-set the circuit breaker...

- Disconnect the **SC-1** from the power outlet.
- Press the black circuit breaker button back in until it clicks.
- Re-connect the **SC-1** to the power outlet.

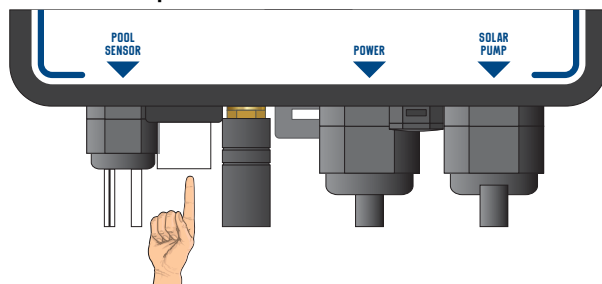



WARRANTY

Australian Energy Systems Pty Ltd (“Australian Energy Systems”) guarantees the **Ultra Solar Controller** to be free from defects in material and workmanship when subjected to normal use and service. This is a limited 3 year warranty, whereby the faulty device is returned to Australian Energy Systems, or Authorised Dealer, freight prepaid within three years from the date of purchase. The faulty device will be repaired and returned, free of charge.

Australian Energy Systems provides the same warranty for the **SC-1W** Wireless Roof Sensor, **SC-1W** Rechargeable Battery Pack and Temperature Sensors, but limited to a period of one year from the date of purchase.

There are no expressed or implied warranties which extend beyond the face hereof, and Australian Energy Systems is not liable for any incidental or consequential damages arising from the use or misuse of this product. This limited warranty does not apply to any injury, loss, damage, defect or malfunction of the product or failure to function resulting from any failure to operate the product in accordance with the directions contained in the operating instructions, failure to function resulting from any accidents, adverse environmental conditions, tampering, abuse, acts, omissions, or negligence by anyone other than Australian Energy Systems, including but not limited to such damage or injuries resulting from improper installation. Damage from excessive concentration of chemicals in the pool water is not covered by this warranty.

This limited warranty shall apply only to the Customer as an original purchaser. It is the customer's responsibility to follow safety regulations and laws regarding electrical installation. Shipping damage is not covered by this warranty.

No claims will be recognised without the proof of purchase. This warranty becomes invalid if unauthorised person or persons attempt modifications or repairs.

Any dispute between customer and Australian Energy Systems must be conducted in Queensland, Australia.



CONTACT US

Australian Energy Systems
Unit 17, 6 Maunder St
Slacks Creek QLD 4127
AUSTRALIA

Tel 1800 243 887
(07) 3299 2700

Email service@poolheating.com.au

Web australianenergysystems.com.au

ABN 87 148 058 495

